

数据手册

MODULETEK: SFP-FE-T-x-D12

100BASE-T SFP(小型可插拔) 电口模块

产品简介

ModuleTek 的 SFP-FE-T 电口模块基于快速以太网 IEEE 802.3 标准和 100BASE-T 标准, 为 FE 应用提供快速可靠的接口, 该产品符合小型可插拔多源协议 (MSA)。

产品特性

- 高达 125Mb/s 的双向数据传输能力
- 符合 SFP MSA
- 热插拔设计
- 缺省不带压制, 软件不可配置
- 支持 100BASE-T 全双工默认操作模式
- 主机系统中支持 100BASE-T 操作
- MDI/MDIX 自适应
- 单电源供电 3.3V
- 符合 RoHS 标准
- 工作温度范围 (外壳温度):
 - 商业温度等级: 0°C 至 70°C
 - 工业温度等级: -40°C 至 85°C

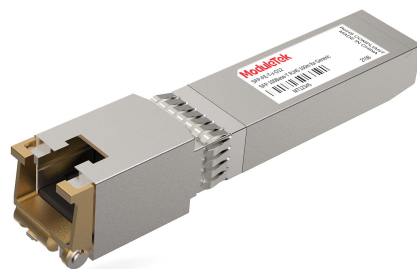

应用

125Mb/s 快速以太网

订购信息

型号	产品 ID	描述	工作温度范围
SFP-FE-T-C-D12	M294402	100BASE-T SFP RJ-45 接口 传输距离可达 100 米, 商业温度	0°C 至 70°C
SFP-FE-T-I-D12	M108902	100BASE-T SFP RJ-45 接口 传输距离可达 100 米, 工业温度	-40°C 至 85°C
注: 1. 该产品带写保护功能 2. 产品 ID 为我司产品标准型号的简写订货号			
如需了解更多信息或订购上述产品, 请联系: 电子邮件: sales@moduletek.com 摩泰光电官网: www.moduletek.com			

产品一般规格

参数	符号	最小值	典型值	最大值	单位	备注
数据速率	DR		100		Mb/s	
传输距离	CL			100	m	1
误码率	BER			10^{-12}		
工作温度	T_C	0		70	°C	2
		-40		85	°C	3
储存温度	T_{STO}	-40		85	°C	4
工作电流	I_{CC}		190	300	mA	5
工作电压	V_{CC}	3.14	3.3	3.46	V	
最大电压	V_{MAX}			4	V	5

注:

- 第 5 类 UTP
- 外壳表面温度, 商业温度
- 外壳表面温度, 工业温度
- 环境温度
- 电接口

标准定义表格

Address A0					
IIC 地址	数据长度	寄存器名称	描述	取值 (HEX)	备注
0	1	Identifier	SFP or SFP+	03	
1	1	Ext. Identifier	GBIC/SFP function is defined by two-wire interface ID only	04	
2	1	Connector	RJ45 (Registered Jack)	22	
3-10	8	Transceiver	Code for electronic or optical compatibility	00 00 00 20 00 00 00 00	
11	1	Encoding	4B/5B	02	
12	1	BR, Nominal	Nominal Bit Rate 100Mb/s	01	
13	1	Rate Identifier	Type of rate select functionality	00	
14	1	Length(SMF,km)	Link length supported for single mode fiber, units of km	00	
15	1	Length (SMF)	Link length supported for single mode fiber, units of 100 m	00	
16	1	Length (50um)	Link length supported for 50 um OM2 fiber, units of 10 m	00	
17	1	Length (62.5um)	Link length supported for 62.5 um OM1 fiber, units of 10 m	00	
18	1	Length (OM4 or copper cable)	100m	64	
19	1	Length (OM3)	Link length supported for 50 um OM3 fiber, units of 10 m	00	
20-35	16	Vendor name	MODULETEK	4D 4F 44 55 4C 45 54 45 4B 20 20 20 20 20 20 20	
36	1	Transceiver	Code for electronic or optical compatibility	00	
37-39	3	Vendor OUI	SFP vendor IEEE company ID	00 00 00	
40-55	16	Vendor PN	Part number in Order information	-	

56-59	4	Vendor rev	Revision level for part number provided by vendor (ASCII)	-	
60-61	2	Wavelength	Laser wavelength (Passive/Active Cable Specification Compliance)	00 00	
62	1	Unallocated		00	
63	1	CC BASE	Check code for Base ID Fields (addresses 0 to 62)	-	
64-65	2	Options	Indicates which optional transceiver signals are implemented	00 00	
66	1	BR, max	Upper bit rate margin	00	
67	1	BR, min	Lower bit rate margin	00	
68-83	16	Vendor SN	Serial number provided by vendor	Programmed by Factory	
84-91	8	Date code	Year,Month,Day	Programmed by Factory	
92	1	Diagnostic Monitoring Type	Indicates which type of diagnostic monitoring is implemented (if any) in the transceiver	00	
93	1	Enhanced Options	Indicates which optional enhanced features are implemented (if any) in the transceiver	00	
94	1	SFF-8472 Compliance	Indicates which revision of SFF-8472 the transceiver complies with.	00	
95	1	CC EXT	Check code for the Extended ID Fields (addresses 64 to 94)	-	
96-127	32	Vendor Specific	Vendor Specific EEPROM	-	
128-255	128	Vendor Specific	Vendor Specific EEPROM	-	
Address A2 Low (商业温度版本)					
IIC 地址	数据长度	寄存器名称	描述	取值 (HEX)	备注
0-1	2	Temp High Alarm	75°C	4B 00	
2-3	2	Temp Low Alarm	-5°C	FB 00	
4-5	2	Temp High Warning	70°C	46 00	
6-7	2	Temp Low Warning	0°C	00 00	
8-9	2	Vcc High Alarm	3.63V	8D CC	

10-11	2	Vcc Low Alarm	2.97V	74 04	
12-13	2	Vcc High Warning	3.46V	87 28	
14-15	2	Vcc Low Warning	3.13V	7A 44	
16-17	2	Bias High Alarm	Bias High Alarm	00 00	
18-19	2	Bias Low Alarm	Bias Low Alarm	00 00	
20-21	2	Bias High Warning	Bias High Warning	00 00	
22-23	2	Bias Low Warning	Bias Low Warning	00 00	
24-25	2	TxPower High Alarm	TxPower High Alarm	00 00	
26-27	2	TxPower Low Alarm	TxPower Low Alarm	00 00	
28-29	2	TxPower High Warning	TxPower High Warning	00 00	
30-31	2	TxPower Low Warning	TxPower Low Warning	00 00	
32-33	2	RxPower High Alarm	RxPower High Alarm	00 00	
34-35	2	RxPower Low Alarm	RxPower Low Alarm	00 00	
36-37	2	RxPower High Warning	RxPower High Warning	00 00	
38-39	2	RxPower Low Warning	RxPower Low Warning	00 00	
40-55	16	Reserved	Reserved	00	
56-59	4	Ext RxPwr 4	Ext RxPwr 4	00 00 00 00	
60-63	4	Ext RxPwr 3	Ext RxPwr 3	00 00 00 00	
64-67	4	Ext RxPwr 2	Ext RxPwr 2	00 00 00 00	
68-71	4	Ext RxPwr 1	Ext RxPwr 1	00 00 00 00	
72-75	4	Ext RxPwr 0	Ext RxPwr 0	00 00 00 00	
76-77	2	Ext Bias Slope	Ext Bias Slope	00 00	
78-79	2	Ext Bias Offset	Ext Bias Offset	00 00	
80-81	2	Ext TxPower Slope	Ext TxPower Slope	00 00	
82-83	2	Ext TxPower Offset	Ext TxPower Offset	00 00	
84-85	2	Ext Temp Slope	Ext Temp Slope	01 00	
86-87	2	Ext Temp Offset	Ext Temp Offset	00 00	
88-89	2	Ext Vcc Slope	Ext Vcc Slope	01 00	
90-91	2	Ext Vcc Offset	Ext Vcc Offset	00 00	
92-94	3	Reserved	Reserved	00	

95	1	Checksum	0-94 Byte Checksum	30	
96-97	2	Temperature	Temperature	-	
98-99	2	Vcc	Vcc	-	
100-101	2	Bias Current	Bias Current	00 00	
102-103	2	Tx Power	Tx Power	00 00	
104-105	2	Rx Power	Rx Power	00 00	
106-109	4	Reserved	Reserved	00 00 00 00	
110	1	Optional Status/ Control Bits	02		
111	1	Reserved	Reserved	00	
112-113	2	Alarm Flags	Alarm Flags	00 00	
114-115	2	Reserved	Reserved	00 00	
116-117	2	Warning Flags	Warning Flags	00 00	
118-121	4	Reserved	Reserved	00 00 00 00	
122	1	Security Level	Security Level: 00=Normal Mode; 01=User Mode (Level 1); 02=Factory Mode (Level 2);	00	
123-126	4	Password Entry	Password Entry Area	00 00 00 00	
127	1	Table Selection	Page Select Byte	00	
Address A2 Low (工业温度版本)					
IIC 地址	数据长度	寄存器名称	描述	取值 (HEX)	备注
0-1	2	Temp High Alarm	90°C	5A 00	
2-3	2	Temp Low Alarm	-45°C	D3 00	
4-5	2	Temp High Warning	85°C	55 00	
6-7	2	Temp Low Warning	-40°C	D8 00	
8-9	2	Vcc High Alarm	3.63V	8D CC	
10-11	2	Vcc Low Alarm	2.97V	74 04	
12-13	2	Vcc High Warning	3.46V	87 28	
14-15	2	Vcc Low Warning	3.13V	7A 44	
16-17	2	Bias High Alarm	Bias High Alarm	00 00	
18-19	2	Bias Low Alarm	Bias Low Alarm	00 00	
20-21	2	Bias High Warning	Bias High Warning	00 00	
22-23	2	Bias Low Warning	Bias Low Warning	00 00	
24-25	2	TxPower High Alarm	TxPower High Alarm	00 00	

26-27	2	TxPower Low Alarm	TxPower Low Alarm	00 00	
28-29	2	TxPower High Warning	TxPower High Warning	00 00	
30-31	2	TxPower Low Warning	TxPower Low Warning	00 00	
32-33	2	RxPower High Alarm	RxPower High Alarm	00 00	
34-35	2	RxPower Low Alarm	RxPower Low Alarm	00 00	
36-37	2	RxPower High Warning	RxPower High Warning	00 00	
38-39	2	RxPower Low Warning	RxPower Low Warning	00 00	
40-55	16	Reserved	Reserved	00	
56-59	4	Ext RxPwr 4	Ext RxPwr 4	00 00 00 00	
60-63	4	Ext RxPwr 3	Ext RxPwr 3	00 00 00 00	
64-67	4	Ext RxPwr 2	Ext RxPwr 2	00 00 00 00	
68-71	4	Ext RxPwr 1	Ext RxPwr 1	00 00 00 00	
72-75	4	Ext RxPwr 0	Ext RxPwr 0	00 00 00 00	
76-77	2	Ext Bias Slope	Ext Bias Slope	00 00	
78-79	2	Ext Bias Offset	Ext Bias Offset	00 00	
80-81	2	Ext TxPower Slope	Ext TxPower Slope	00 00	
82-83	2	Ext TxPower Offset	Ext TxPower Offset	00 00	
84-85	2	Ext Temp Slope	Ext Temp Slope	01 00	
86-87	2	Ext Temp Offset	Ext Temp Offset	00 00	
88-89	2	Ext Vcc Slope	Ext Vcc Slope	01 00	
90-91	2	Ext Vcc Offset	Ext Vcc Offset	00 00	
92-94	3	Reserved	Reserved	00	
95	1	Checksum	0-94 Byte Checksum	30	
96-97	2	Temperature	Temperature	-	
98-99	2	Vcc	Vcc	-	
100-101	2	Bias Current	Bias Current	00 00	
102-103	2	Tx Power	Tx Power	00 00	
104-105	2	Rx Power	Rx Power	00 00	
106-109	4	Reserved	Reserved	00 00 00 00	
110	1	Optional Status/ Control Bits	02		

111	1	Reserved	Reserved	00	
112-113	2	Alarm Flags	Alarm Flags	00 00	
114-115	2	Reserved	Reserved	00 00	
116-117	2	Warning Flags	Warning Flags	00 00	
118-121	4	Reserved	Reserved	00 00 00 00	
122	1	Security Level	Security Level: 00=Normal Mode; 01=User Mode (Level 1); 02=Factory Mode (Level 2);	00	
123-126	4	Password Entry	Password Entry Area	00 00 00 00	
127	1	Table Selection	Page Select Byte	00	
Address A2 Page 00h					
IIC 地址	数据长度	寄存器名称	描述	取值 (HEX)	备注
128-255	128	Upper Memory Map	User Code Area	-	
Address A2 Page 8Ah					
IIC 地址	数据长度	寄存器名称	描述	取值 (HEX)	备注
128-131	4	Firmware Version Number[4]	Firmware Version Number	-	
132-135	4	Total Running Time In Second	Total Running Time In Second	-	
Address A2 Page F0h					
IIC 地址	数据长度	寄存器名称	描述	取值 (HEX)	备注
128-131	4	Password1 Long	Level 1 Password	00 00 10 11	
132	1	Disable A0 WP	00=A0 With Write Protection; 01=A0 Without Write Protection	00	
133	1	Disable A2T00T01 WP	00=A2 T00T01 With Write Protection; 01=A2 T00T01 Without Write Protection	00	

注:

1. 写密码区缺省为 00000000, 读出为最后的写入值

用户模式

安全等级 1 缺省密码	密码是否可改	权限
00 00 10 11	是 (A2 TF0)	1、可读写 A0、A2 T00
		2、可读 A2 T8A
		3、可读写 A2 TF0

注:

1. 寄存器详情见标准定义表格。

外形尺寸

模块重量: 25.0g

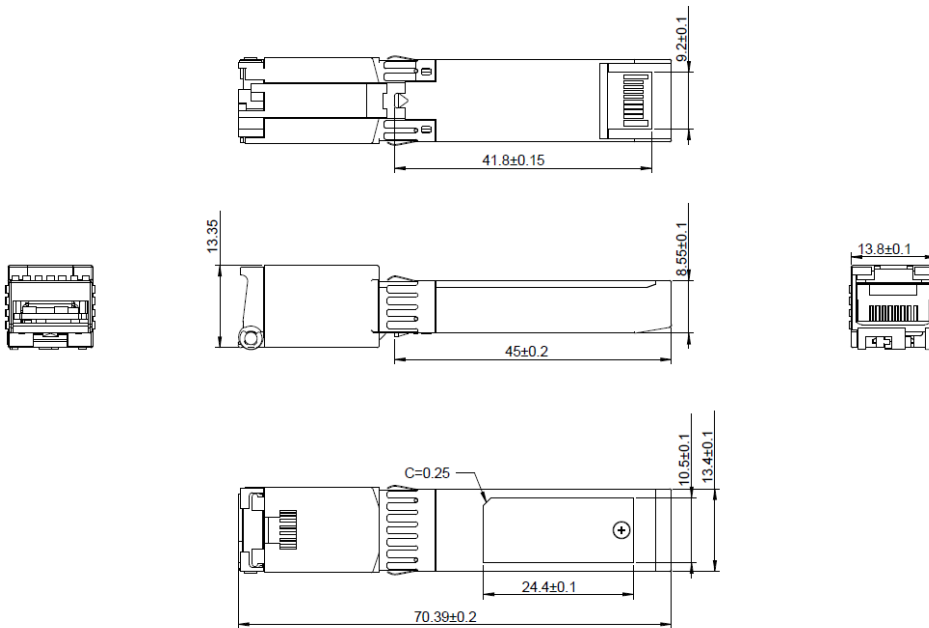

未注尺寸公差 $\pm 0.2\text{mm}$
单位: 毫米

引脚图

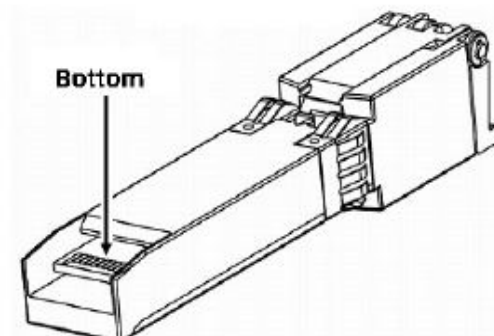
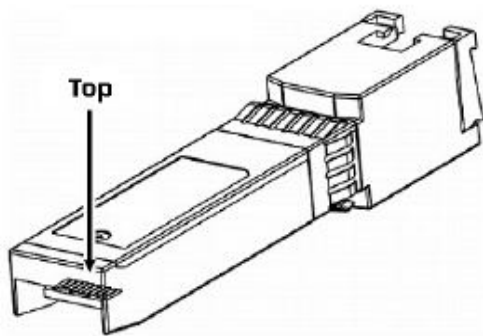
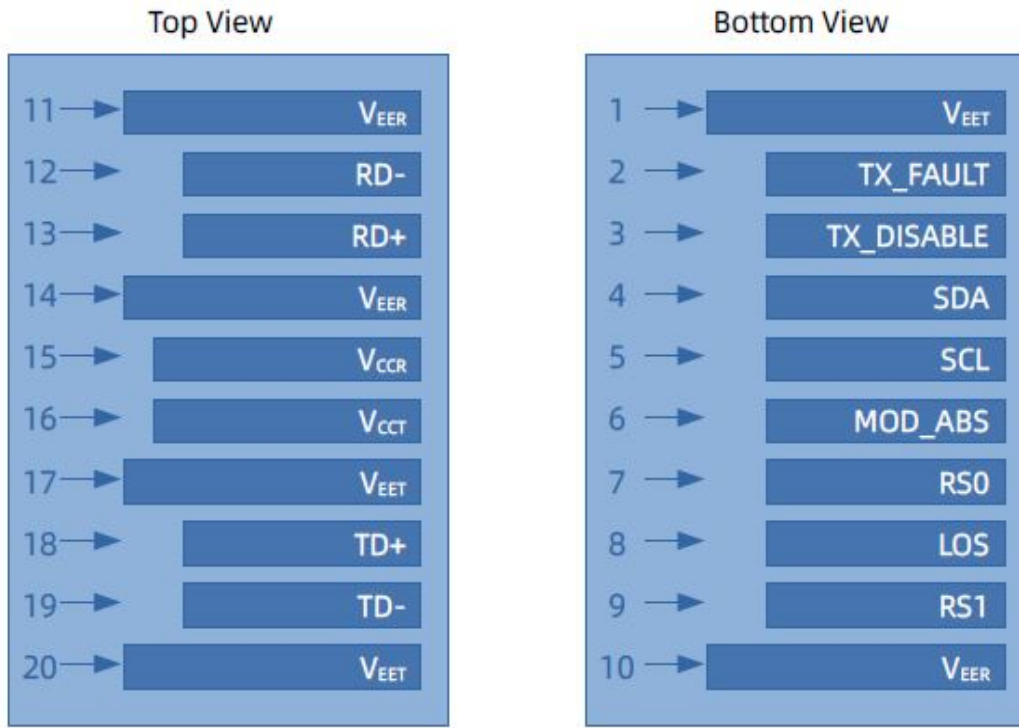

引脚定义

PIN #	符号	说明	备注
1	V _{EET}	发射端地 (与接收端地共用)	1
2	T _{FAULT}	发射端故障告警	
3	T _{DIS}	该信号高电平或开路时禁用 PHY	2
4	MOD_DEF(2)	两线串行接口数据线	3
5	MOD_DEF(1)	两线串行接口时钟线	3
6	MOD_DEF(0)	模块插入指示引脚	3
7	Rate Select	未连接	
8	LOS	信号丢失指示, 低电平表示模块正常工作	
9	V _{EER}	接收端地 (与发射端地共用)	1
10	V _{EER}	接收端地 (与发射端地共用)	1
11	V _{EER}	接收端地 (与发射端地共用)	1
12	RD-	接收端数据输出负, 交流耦合	
13	RD+	接收端数据输出正, 交流耦合	
14	V _{EER}	接收端地 (与发射端地共用)	1
15	V _{CCR}	接收端电源	
16	V _{CCT}	发射端电源	
17	V _{EET}	发射端地 (与接收端地共用)	1
18	TD+	发射端数据输入正, 交流耦合	
19	TD-	发射端数据输入负, 交流耦合	
20	V _{EET}	发射端地 (与接收端地共用)	1

注:

1. 电路地与模块外壳是绝缘的
2. 禁用: T_{DIS}>2V 或开路, 使能: T_{DIS}<0.8V
3. 应在主机板上以 4.7kΩ-10kΩ 的电阻上拉到 2V 至 3.6V 之间的电压

参考文献

1. IEEE standard 802.3. IEEE Standard Department, 2002.
2. Small Form Factor Pluggable (SFP) Transceiver Multi-Source Agreement (MSA), September 2000.